

A product designed for both conventional and analogue addressable fire alarm systems. Available as a visual indicator and audible/visual indicator, the Identifire Remote Lamp Unit can be easily retrofitted to existing systems or incorporated as part of a new installation.

As with the wider Identifire range, the product is designed to fit any recessed single gang box, giving a flush finish or surface mounted using the Identifire surface box.

In common with all other Identifire products, our Remote Lamp Unit can be customised with your choice of logo and text in any language\*



## Specification

Operating Voltage	12 - 28 Vdc
Current Consumption	22mA (Conventional)/Addressable - detector dependant
Weight	0.06 kg
Housing Material	Fire rated ABS
Operating Temperature	-5°C to +50°C
Colour	Red/White
Material	Fire Rated ABS



**Flush Mounted**



**Surface Mounted**

## IDENTIFIRE

### Features

- / Aesthetically appealing design
- / Low Current Consumption
- / Features 4 x 20mm knockouts for surface and glanded entry
- / Simple installation for new or retrofit applications
- / Available with/without Buzzer (Buzzer can be disabled via Jumper link)
- / Will operate at 12 and 24 Vdc

### Approvals

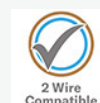

\*Minimum order quantities/ setup charge may apply

Identifire product is compatible with 2 wire fire alarm systems.  
List of compatible control panels available

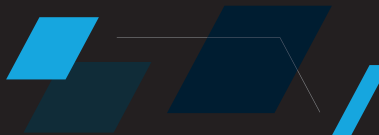

## Part Numbers

10-2011WFR-S  
 10-2011WSR-S  
 10-2111WFR-S  
 10-2111WSR-S

Identifire Remote Lamp Unit, White, Flush  
 Identifire Remote Lamp Unit, White, Surface  
 Identifire Remote Lamp Unit with Buzzer, White, Flush  
 Identifire Remote Lamp Unit with Buzzer, White, Surface

## Spares & Accessories

10-8010RXX  
 10-8010WXX

Identifire Back Box, Red  
 Identifire Back Box, White

## TECHNICAL DRAWING

### Back Cover

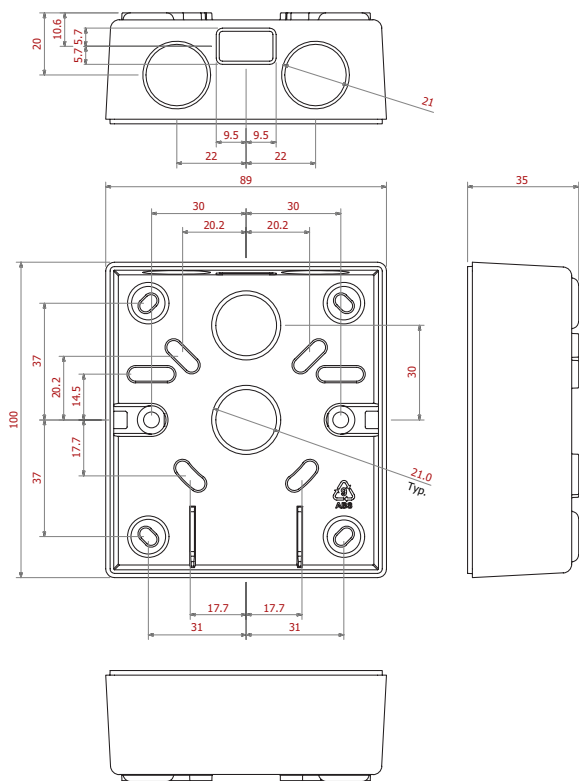

### Remote Lamp Unit

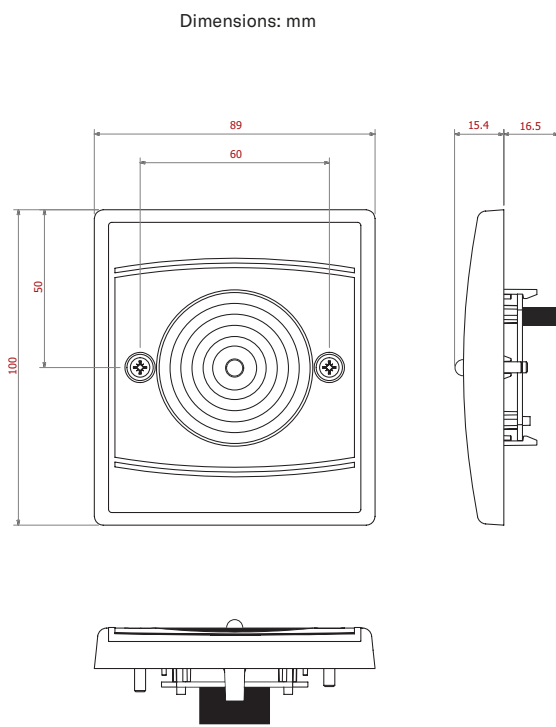

3700035\_REV301

We reserve the right to change or amend any design or specification in line with our policy of continuing development and improvement.

Vimpex Ltd, Star Lane, Great Wakering, Essex, SS3 0PJ, UK  
 Vimpex Europe BV / Vimpex Sweden AB /

+44 (0) 1702 216 999 / sales@vimpex.co.uk / vimpex.co.uk

Registered in England No.2915112 Registered Address: Star Lane, Great Wakering, Essex, SS30PJ, United Kingdom



Quality System Certificate No. 456  
 Assessed to ISO 9001

