

## UK Full Manual

### General Information

Read the instructions before commencing installation. The user is to retain the instructions for future reference.

- Espire Alarms have been designed and developed for fixed residential installation and use.
- The Alarm is required to be permanently wired to a 230V mains electrical supply by a qualified electrician in accordance with the local wiring regulations.
- Before commencing electrical work, ensure the mains isolator on the consumer unit is in the 'OFF' position to prevent electric shock and ensure the Alarm is complete with the Lock-in Wiring Base.
- After installation the Alarm is to be tested weekly: Press and hold the Test/ Hush button for at least 10 seconds to ensure the Alarm sounds and all interconnected Alarms activate.

### Product Description

- ES1SLV Optical Smoke Alarm Powered by Mains Supply with a Sealed 10 Year Lithium Battery
- ES1HLV Heat Alarm Powered by Mains Supply with a Sealed 10 Year Lithium Battery
- ES1MULV Optical Smoke and Heat Multi-Sensor Alarm Powered by Mains Supply with a Sealed 10 Year Lithium Battery

The Alarm is supplied with a Lock-In Wiring Base.  
 The RF-Link (ES1RF) module is supplied with the Alarm or available separately.  
 The Alarm's backup battery is sealed and non-replaceable.

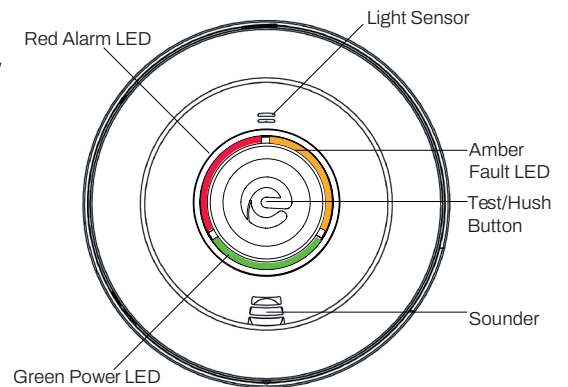

### Recommended Alarm Location

Alarm locations are to follow guidance provided in British Standard; BS 5839-6:2019.

A Fire Risk Assessment is used to determine the Grade and Category of system required;

#### LD1 OPTIMUM PROTECTION

Appropriate where occupants are likely to be vulnerable (e.g the elderly.) In addition to LD3 recommendations, Alarms are installed in all circulation areas and all rooms or areas in which fire might start. Excludes toilets, bathrooms or shower rooms.

#### LD2 BASIC PROTECTION

In addition to the recommendations for an LD3 system, additional Alarms are installed in certain rooms determined by the risk assessment. For example; a heat Alarm is installed in each kitchen, or a smoke Alarm installed in the living room. Excludes toilets, bathrooms or shower rooms.

#### LD3 MINIMUM PROTECTION

Alarms installed in all hallways, stairways and circulation areas that form part of the escape routes. All Alarms are to be interconnected.

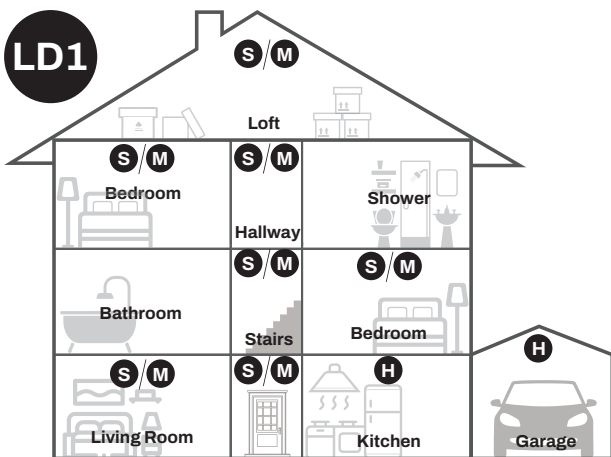

Multi Storey Dwelling Example

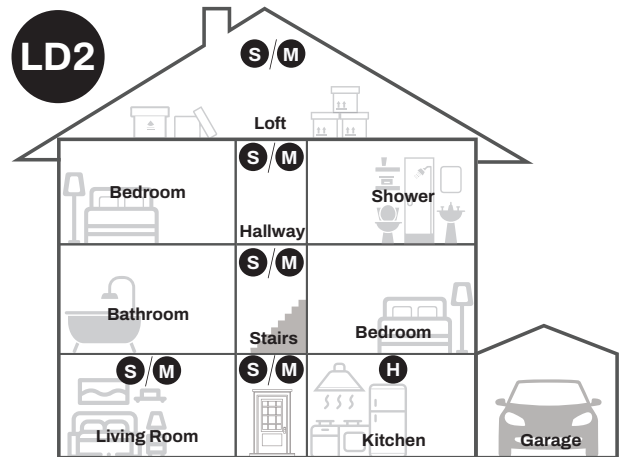

Multi Storey Dwelling Example

#### Diagram Key

- S** ES1SLV Optical Smoke Alarm    **H** ES1HLV Heat Alarm    **M** ES1MULV Multi-Sensor Alarm

## Alarm Installation

Alarm Installations are to follow guidance provided in British Standard; BS 5839-6:2019.

- For optimum performance the preferred location for the Alarm is a central ceiling position, and at least 300mm from walls and any objects such as light fittings. It should be mounted on a flat surface, with no obstructions such as existing pipes or wiring
- Avoid the following locations: sources of high humidity, condensation or steam, such as bathrooms and shower rooms; extreme temperatures exceeding 40°C or below 0°C; close to sources of heat or cool air which cause sudden temperature fluctuations.

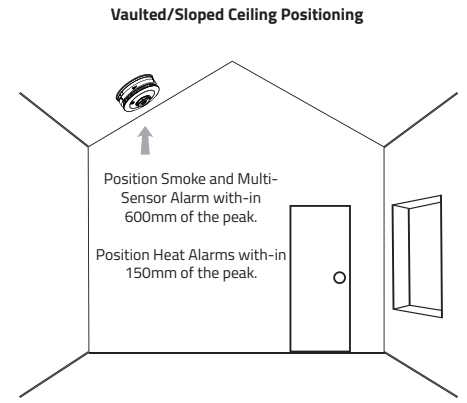
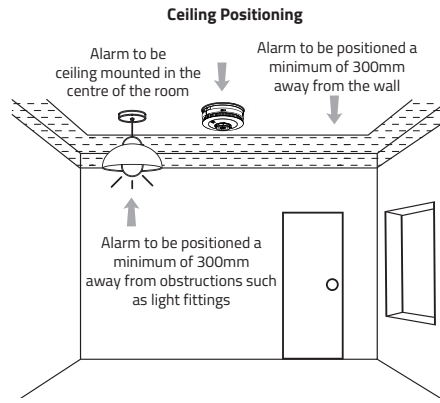

## Alarm Connections

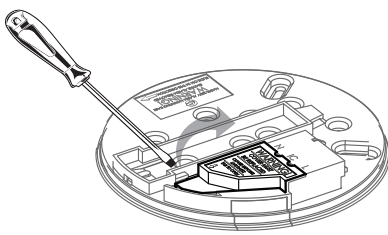

**Step 1.**  
On the Lock-in Wiring Base remove the cover for the wiring terminal block using a flathead screwdriver.

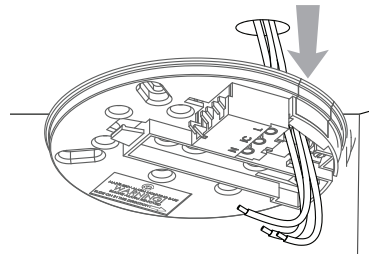

**Step 2.**  
Lead recessed wires through the rear entry of the base.

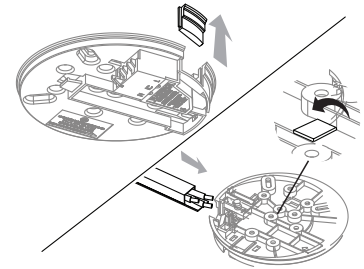

**Step 3.**  
For surface wiring; slide the trunking clip away from the base.

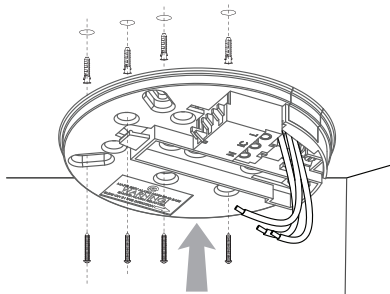

**Step 4.**  
Using the base, mark the desired mounting holes, drill and re-align the base, screwing into place. Multiple mounting holes are available for retro fit installations.

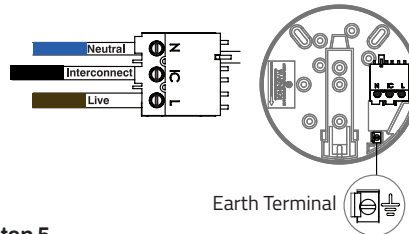

**Step 5.**  
Connect the wires to the terminal block;  
L: Live (Brown), N: Neutral (Blue),  
IC: Interconnect (UK/Black) or (ROI/White)  
 : Earth Terminal (Green & Yellow)  
The Alarm is not required to be Earthed, the Earth Terminal has been provided for safe termination.

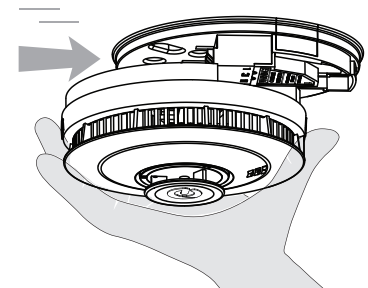

**Step 6.**  
Replace the terminal block cover as shown in Step 1, and carefully line up the Alarm to the base and slide on until secured and a 'click' is heard.

**Step 8.**  
After the wiring connections have been made and checked, connect the mains power supply. Check that the Red LED flashes at 40 second intervals to show that the Alarm is functioning and the Green power status LED is permanently illuminated.

## Alarm Testing

Test the Alarm after installation, and weekly thereafter.

Check that the Red LED flashes at 40 second intervals to show that the Alarm is functioning and the Green power status LED is permanently illuminated.

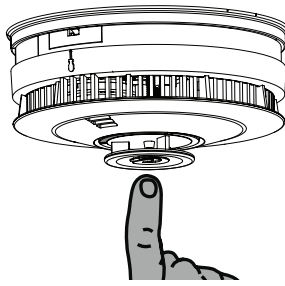

### Step 1.

Press and hold the Test/Hush button for a minimum of 10 seconds.

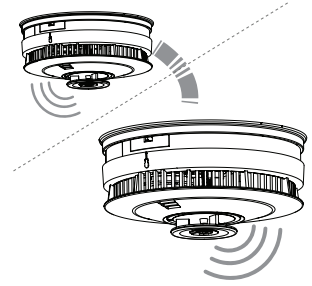

### Step 2.

The Alarm will sound and the Red LED will flash.

## Interconnected Wiring Installation

- A maximum of 28 Alarms can be interconnected.
- In the event of an Alarm activation all Alarms will sound. The Alarm that triggered the activation will display the Red LED
- Do not connect Espire Alarms to any other type of Alarm produced by another manufacturer.
- Using the incorrect wiring connections is likely to damage all the Alarms connected to the system.
- The interconnect wire (minimum 1mm<sup>2</sup> cable) should be insulated and sheathed. A maximum of 300 metres of wire can be used.

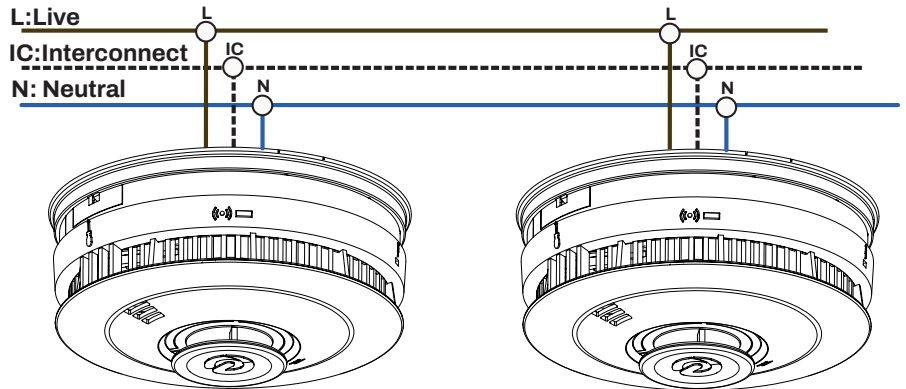

Heat Alarms must always be interconnected to a smoke or multi-sensor Alarm to ensure early warning.

## RF-Link Introduction

Up to 28 Alarms can be interconnected wirelessly via the RF-Link function. Ensure the Alarms have been fitted with the RF-Link module. Prior to RF Coding, ensure that all system Alarms are correctly wired, powered and functioning independently.

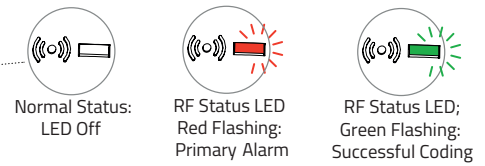
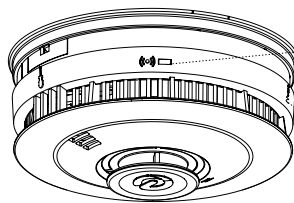

The RF Coding Switch is located on the side of the Alarm, marked with the Tool symbol.



## RF-Link Coding

• As default the RF-Link modules are universally coded together. It is important to carry out the Alarm RF coding procedure to ensure the system operates independently from other nearby Espire Alarm systems.

• The first Alarm that enters RF Coding Mode will be assigned as the 'PRIMARY', all other Alarms will be assigned as a 'SECONDARY'. It is important to mark the PRIMARY Alarm with the label provided for future servicing of the system.

## Alarm RF Coding

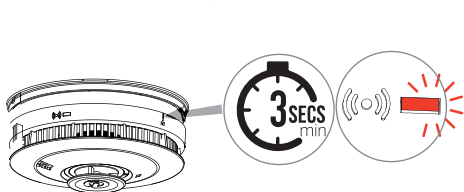

### Step 1.

Using the supplied pairing tool press and hold the RF Coding Switch on one of the system's Alarms for a minimum of 3 seconds and release when the RF Status LED flashes Red.

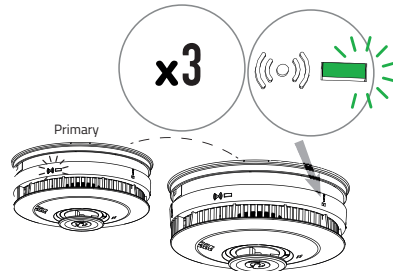

### Step 2.

While the PRIMARY Alarm is in coding mode, at the next Alarm press the RF Coding Switch 3 times and the RF Status LED will turn Green to confirm successful coding. Repeat the process on the remaining Alarms.

**Note:** RF Coding Mode will be active for 30 minutes before auto time out.

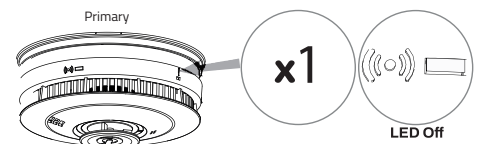

### Step 3.

Once all the Alarms have been coded to the PRIMARY Alarm, return to the PRIMARY Alarm and single press the RF Coding Switch and the RF Status LED will stop flashing. RF Coding Mode has now ended.

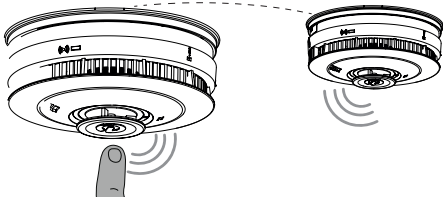

**Step 4.**

After coding is completed, test each individual Alarm and check that all interconnected Alarms sound.

**Note:** There may be up to a 10 second delay for the coded Alarms to respond after pressing the Test/Hush button.

**Delete an RF-Link Coded Alarm**

Press and hold the RF Coding Switch for 3 seconds and release when the RF Coding Status LED flashes Red.

Single press the RF Coding Switch to confirm deletion, the RF Status LED will stop flashing.

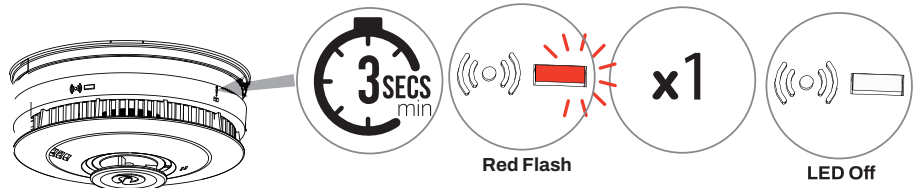

**Important:** If the PRIMARY Alarm is deleted, the system will require re-coding.

**Alternative RF-Link System Setup**

- Hybrid System; Systems that incorporate hardwired and RF-Link Alarms, consult the RF-Link module manual (ES1RF) for limitations and further guidance.
- Remote Control System; Systems that incorporate the Espire Remote Control, consult the Remote Control manual (ES1REM), for limitations and further guidance.

**Alarm Maintenance and Cleaning**

To avoid false alarms, clean the Alarm regularly to avoid debris build up from dust and insects. In dusty areas it may be necessary to clean the Alarm more frequently. Use a vacuum to remove dust build up and clean with a damp cloth, do not use cleaning products. Dry the Alarm thoroughly after cleaning.

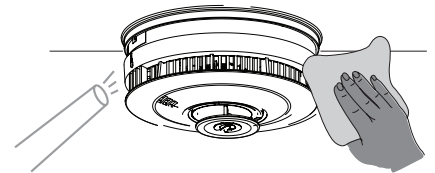

**Alarm Removal**

Isolate the mains power supply prior to the removal of the Alarm.

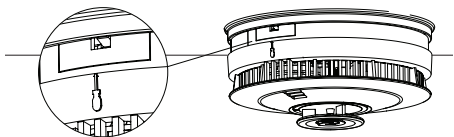

**Step 1.**  
Locate the screwdriver symbol on the side of the Alarm.

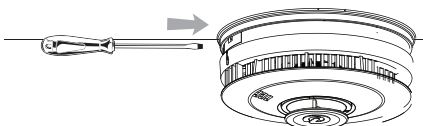

**Step 2.**  
Insert a flathead screwdriver horizontally into the centre of the release lever.

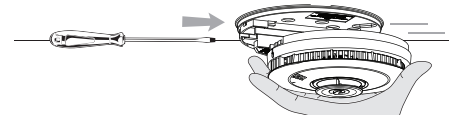

**Step 3.**  
With the screwdriver in place, push away the lower half of the Alarm from the screwdriver.

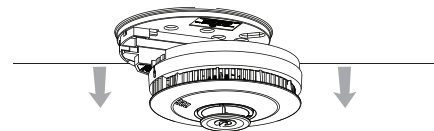

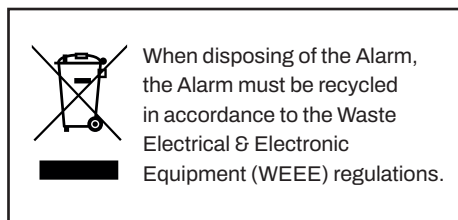

**Step 4.**  
Hold the lower half of the Alarm and remove from the base.





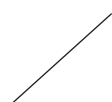



## Alarm Status Indication

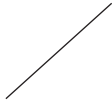
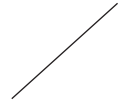

### Normal Mode

Green LED	Amber LED	Red LED	Sounder	Description
		 1 x 40 sec		(i) A steady Green LED means that the power supply to the Alarm is normal. (ii) The Red LED flashes every 40 seconds to coincide with the Alarm's auto test function. <b>Note:</b> The Auto Dim LED function automatically adjusts the brightness of the Green LED up to 50% in low light conditions such as at night to reduce distraction.



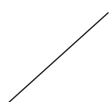

### Alarm Activation

Green LED	Amber LED	Red LED	Sounder	Description
				When the Red LED flashes and the Alarm is sounding the Alarm has been activated. <b>Warning:</b> If there is any doubt about the cause of an Alarm activation assume it was caused by an actual fire and evacuate immediately.
				An interconnected Alarm has been activated.





### Memory Mode

Green LED	Amber LED	Red LED	Sounder	Description
		 2 x 40 sec		(i) The Red LED flashes twice every 40 seconds to indicate the Alarm has stored an activation in the memory. (ii) Memory function assists identification of Alarms that have been activated. (iii) The memory will automatically clear after 24 hours of the activation or press and hold the 'Test/Hush' button until the Red LED flashes twice and the Alarm sounds twice.









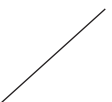
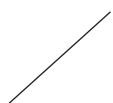

### Hush Mode

Green LED	Amber LED	Red LED	Sounder	Description
		 1 x 8 sec		(i) During an Alarm activation if the 'Test/Hush' button is pressed the Alarm will enter Hush mode for 10 minutes before returning automatically to normal state. (ii) If the Red LED flashes every 8 seconds; the Alarm is in Hush mode and the sensor remains in activated state.









### Contamination Mode (Smoke Sensor Only)

Green LED	Amber LED	Red LED	Sounder	Description
	 4 x		 4 x	(i) If the 'Test/Hush' button is pressed and the Amber LED flashes with the Alarm sounding four times; this indicates the Alarm's optical smoke chamber is contaminated. Dust is one of the main causes. (ii) Alarm cleaning and maintenance must be completed regularly.



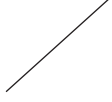

### Fault Mode

Green LED	Amber LED	Red LED	Sounder	Fault	Solution	Description
		 1 x 40 sec		AC Mains Off	Establish AC Mains Power	In the event that the mains supply is not detected by the Alarm; Check the circuit breaker, power supply wiring and connections. If there is any doubt contact a qualified electrician.
	 1 x 40 sec		 1 x 40 sec	AC Mains Off Low Battery Backup	Replace Alarm	If the backup battery is depleted and the Green LED is off, the Alarm will sound and the Amber LED flashes once every 40 seconds.
	 1 x 40 sec		 1 x 40 sec	Low Battery Backup	Replace Alarm	If the backup battery is depleted but the Green Power LED is on, the Alarm will sound and the Amber LED flashes once every 40 seconds.

## Fault Mode

Green LED	Amber LED	Red LED	Sounder	Fault	Solution	Description
	 2 x 40 sec		 2 x 40 sec	Alarm Fault	Replace Alarm	The Alarm performs automatic tests. If the Alarm detects an internal error the Alarm will sound and the Amber LED flashes twice every 40 seconds.
	 3 x 40 sec		 3 x 40 sec	End of Life	Replace Alarm	After the Alarm passes the 10th year of installation it performs an End Of Life cycle indicating that the Alarm is recommended to be replaced. The Alarm will sound and the Amber LED flashes three times every 40 seconds

## Fault Hush Mode

Green LED	Amber LED	Red LED	Sounder	Description
	 40 sec			(i) The Amber LED flashes every 40 seconds to indicate the Alarm is in Fault Hush mode for 12 hours (ii) Low battery fault and End of life fault can be hushed more than once. Sensor fault can only be hushed once

## Product Safety

- If there is any doubt about the cause of an Alarm activation, assume it was caused by an actual fire and evacuate immediately.
- Read and retain all instructions.
- Test Alarms regularly.
- Ensure emergency escape plans are in place (Contact the local fire prevention officer for more information).
- Do not paint or cover the Alarm.
- Do not attempt to repair the Alarm.
- Do not dispose of the Alarm in a fire.
- Do not expose the Alarm to wet and/or humid conditions, indoor use only.
- The Alarm shall not be exposed to dripping or splashing and no objects filled with liquids, such as vases, shall be placed on the Alarm.
- Batteries (battery pack or batteries installed) shall not be exposed to excessive heat such as sunshine or the like.
- Any remote silencing feature shall only be used in line of sight of the Alarm

## Product Service

- If an Alarm fails to function as per the instructions contact the distributor.
- If advised to return the Alarm, ensure the wiring base is disconnected as the Test/Hush button will still be active. Complete all information that has been requested and return in a securely packaged shipment.
- The Alarm is covered by a 5-year warranty, the warranty period starts from the date an authorised distributor purchases the Alarm.
- The warranty covers defects arising from manufacturing processes. The warranty does not cover damage accidental or otherwise, contamination and unauthorised repair.

## Product Limitations

- Espire Alarms have been designed and developed for fixed residential installation and use.
- Alarms should be installed by a competent person and sited according to relevant standards.
- The Alarm will not work if a mains power supply is not present at the wiring terminal block and the sealed battery is depleted.
- The Alarm may not be heard for a number of reasons, for example; Alarm is positioned too far away from the occupants, occupants are impaired or high background noise. Interconnecting a number of Alarms improves the chances of hearing an Alarm sounding.
- The Alarm may not detect every type of fire.
- Replace the Alarm by the date specified on the product or within 10 years of installation, whichever is first.

## Product Installation

- To avoid serious risk of electric shock or fire hazards. Alarms are to be installed and interconnected by a qualified electrician in accordance with the local electrical Installations regulations BS 7671.
- BS 5839-6:2019 provides recommendations regarding the mains supply for a Grade D system;

The power supply for the Alarms should be derived from the public electricity supply to the dwelling. The mains supply to the Alarms should take the form of either:

- (i) An independent circuit at the dwelling's main distribution board, in which case no other electrical equipment should be connected to this circuit (other than the supply to a dedicated social alarm control unit)
- (ii) or a separately electrically protected, regularly used local lighting circuit

- The Alarm is designed to be permanently fixed and to be supplied with a continuous mains supply using the provided wiring base.
- This Alarm is designed to be connected 230V 50Hz AC supply only.
- Energy sources using inverters must ensure the Total Harmonic Distortion (THD) is less than 5%.
- Do not power the Alarm from a lighting dimmer circuit or from a circuit that can be switched off.
- Do not perform insulation test on the Alarm.
- Ensure the Alarm cover that protects the Alarm has been removed only when the site location has been cleaned thoroughly. The Alarm will not function correctly with the cover fitted.

## Product Specification

- Visit [www.espireuk.com](http://www.espireuk.com) for the latest product data.

