

# ESPIRE

Product Code: ES1CHLV

Description: Carbon Monoxide and Heat Multi-Sensor Alarm Powered by Mains with a 10 Year Lithium Battery

## Technical Specification Multi-Sensor Alarm

Luckinslive 437540285

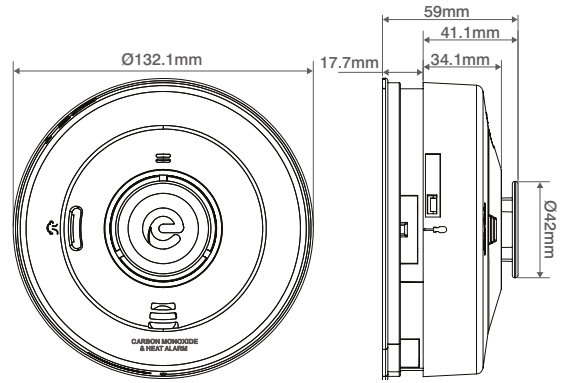

### General Information

Dimensions (mm)	Ø132 x 59
Colour	White
Materials	UL94-V0 rated UV stabilised ABS
Mounting	Ceiling
Recommended Installation Locations	Fuel Burning Areas & Kitchen Areas
Indication	3 LEDs; Green - Power, Yellow - Fault, Red - Fire / CO
Auto Dim Power LED	Day Mode and Night Mode (Not intrusive to sleep)
Manual Test Button	Checks sensor, electronics & sounder
Weight (Kg)	0.268
Warranty (Years)	5

### Technical

Sensor Type	Multi Sensor; Sensor 1 - Carbon Monoxide Sensor 2 - Heat
Heat Detection Class	A2
Heat Detection Temperature (°C)	58
Sounder Output (dB)	85 @ 3m
Hush Function	Alarm hush - 10 minutes, Fault hush - 12 hours
CO Detection Levels	Low - ≤50 PPM, Medium - ≤100 PPM, High - ≤180 PPM
Installation Grade	D1

### Supply, Power & Backup

Supply Type	Mains AC with battery backup
Supply Voltage (V AC)	230
Frequency (Hz)	50
Maximum Power Consumption (W)	3.3
Standby Power Consumption (W)	0.5
Battery Backup	Non-replaceable 10 Year Battery
Battery Type	3V Lithium
Battery Size	CR123A
Battery Chemistry	Lithium
Battery Lifetime	10 Year

### Interconnectability

Wired Interconnect Supported	Yes
Maximum Interconnect Wiring Distance (m)	300
RF-LINK Supported	Yes; Requires ES1RF
Maximum Supported Wired & RF-LINK Interconnected Devices	28
Base Type	Anti-Tamper Lock-In Wiring Base

### Environment

Operating Temperature (°C)	0 to +40
Relative Humidity Resistance (%)	95 (non-condensing)

Unit 7 Target Park, Shawbank Road,  
Lakeside, Redditch B98 8YN United Kingdom  
T: +44 (0)1527 515150 | F: +44 (0)1527 515143  
E: info@espuke.com | W: espuke.com



CLICK OR SCAN

Catalogue



DoC



Installation



Quick Start



CLICK OR SCAN

# ESPIRE

Product Code: ES1CHLV

Description: Carbon Monoxide and Heat Multi-Sensor Alarm Powered by Mains with a 10 Year Lithium Battery

## Technical Specification Multi-Sensor Alarm

Luckinslive 437540285



### Accessories

- ES1RF: Alarm RF-Link Module
- ES1MP: Alarm Masking Plate
- ES1MTW: Alarm Multi Tool (2 Pack) White
- ES1MTB: Alarm Multi Tool (2 Pack) Black

### Features

- 24 hour memory function
- Clear LED indication status

Unit 7 Target Park, Shawbank Road,  
Lakeside, Redditch B98 8YN United Kingdom  
**T:** +44 (0)1527 515150 | **F:** +44 (0)1527 515143  
**E:** info@espuk.com | **W:** espuk.com



CLICK OR SCAN



CLICK OR SCAN



CLICK OR SCAN