

Discovery

Carbon Monoxide Detector



Product overview

Product	Carbon Monoxide Detector
Part No.	58000-300
Digital Communication	XP95, Discovery and CoreProtocol® compatible

Product information

The Discovery Carbon Monoxide (CO) Detector is an analogue addressable fire detector that has the features that follow:

- Early warning of carbon based smouldering fires
- Resistance to false alarms in areas with high levels of steam and other airborne particles
- Ideal for protecting small volume sleeping risk areas
- Resistance to contamination in dirty and dusty conditions
- Excellent supplement to fire detection systems to improve detection of smouldering hydrocarbon fires

Note: The Discovery CO Detector is not compatible for use with the XP95 Isolating Base Part No: 45681-321

Technical data

All data is supplied subject to change without notice. Specifications are typical at 24 V, 25°C and 50% RH unless otherwise stated.

Detection principle	Ambient Carbon Monoxide level								
Operating voltage	17 - 28V dc								
Supply Wiring	Two wire supply, polarity sensitive								
Terminal functions	<table border="0"> <tr> <td>L1</td> <td>Loop in & out negative</td> </tr> <tr> <td>L2</td> <td>Loop in and out positive</td> </tr> <tr> <td>+R</td> <td>Remote indicator positive connection (internal 2.2 kΩ resistance to supply +ve)</td> </tr> <tr> <td>-R</td> <td>Remote indicator negative connection (internal 2.2 kΩ resistance to supply -ve)</td> </tr> </table>	L1	Loop in & out negative	L2	Loop in and out positive	+R	Remote indicator positive connection (internal 2.2 kΩ resistance to supply +ve)	-R	Remote indicator negative connection (internal 2.2 kΩ resistance to supply -ve)
L1	Loop in & out negative								
L2	Loop in and out positive								
+R	Remote indicator positive connection (internal 2.2 kΩ resistance to supply +ve)								
-R	Remote indicator negative connection (internal 2.2 kΩ resistance to supply -ve)								
Digital communication protocol	XP95, Discovery and CoreProtocol compatible								
Modulation voltage	5-9 V peak to peak								
Quiescent current	500 μA average, 750 μA peak								
Power-up surge current	1 mA								
Maximum power-up time*	10 seconds								
Alarm indicator	Two red light emitting diodes (LEDs) Optional remote LED								
Alarm current, LED illuminated	3.5 mA								
Remote output characteristics	Connects to positive line through 4.5 kΩ (5 mA maximum)								
Sampling frequency	Once per second								
Clean-air analogue value	25 ± 2								
Operating temperature	<table border="0"> <tr> <td>Continuous</td> <td>0°C to +50°C</td> </tr> <tr> <td>Transient</td> <td>-20°C to +55°C</td> </tr> </table>	Continuous	0°C to +50°C	Transient	-20°C to +55°C				
Continuous	0°C to +50°C								
Transient	-20°C to +55°C								
Operating pressure	Suitable for installation up to 2,000 m above sea level								
Storage temperature	<table border="0"> <tr> <td>Continuous</td> <td>-10°C to 30°C</td> </tr> <tr> <td>Transient</td> <td>-40°C to 55°C</td> </tr> </table>	Continuous	-10°C to 30°C	Transient	-40°C to 55°C				
Continuous	-10°C to 30°C								
Transient	-40°C to 55°C								
Storage pressure	If air freighted this product should be placed in a pressurised hold								
Humidity	15% to 90% RH								
Effect of temperature	Less than 15% change in sensitivity over rated range								
Effect of wind	None								
IP rating	IP44								
Vibration, impact and shock	ISO209-1								
Standards and approvals	IEC60068-2-6, IEC60068-2-27								
Cell life	5 years - assuming satisfactory regular checks								
Dimensions	100 mm diameter x 42 mm height								
Weight	94.2 g								
Materials	Housing: White flame-retardant polycarbonate Terminals: Nickel plated stainless steel								

36 Brookside Road, Havant | Tel: +44 (0)23 9249 2412 | Email: sales@apollo-fire.com
 Hampshire, PO9 1JR, UK. | Fax: +44 (0)23 9249 2754 | Web: www.apollo-fire.co.uk

All information in this document is given in good faith but Apollo Fire Detectors Ltd cannot be held responsible for any omissions or errors. The company reserves the right to change the specifications of products at any time and without prior notice.

Carbon Monoxide detection of fire

All carbon based materials in the smouldering, red ember stage of a fire can produce significant and easily detectable levels of CO.

CO levels can therefore be monitored in order to give an early warning of fire.

Exposure to CO is potentially lethal at concentrations above 300 parts per million (ppm) and at higher concentrations can cause death within minutes. Lethal levels of CO are most likely to be produced when a fire starts in an enclosed space with limited ventilation. In such cases a fire in a late smouldering state will deplete oxygen in the enclosure and produce very high CO levels in the range 10,000 to 50,000 ppm.

Operating principles

Discovery CO fire detectors contain a long-life electro-chemical carbon monoxide sensor which is tolerant of low levels of common vapours and household products. The sensing technology is fast, accurate and needs only very low power. These factors make the CO sensor suitable for fire detection applications.

The detection capabilities are enhanced by rate-sensitive response. Fast rises in the CO level are often associated with hot fires and the detector will respond earlier under these conditions. The analogue reply from the detector is rate limited to remove nuisance alarms resulting from short-term high levels caused by sources such as pipe smokers or gas flame ignition.

Application



CAUTION: Application

CO detectors do not detect smoke particles or heat and are not universal replacements for smoke detectors.

Apollo **DOES NOT** endorse the use of CO detectors as the main method of fire detection if:

- The protected area is an escape route
- There is a requirement to detect overheating of electrical equipment or cables
- The protected area is exposed to sources of CO such as vehicle exhausts, hydrogen or high levels of alcohol vapour as emitted by some cleaning agents
- There is a requirement to detect fires involving flammable liquids

CO fire detectors are particularly suitable for **supplementing** smoke detectors when there is:

- A deep seated, smouldering fire risk
- A risk of fire starting in an enclosed space
- A likelihood of stratification taking place

CO detectors may be used as the **primary** fire detector in areas where the conditions that follow exist

- The main risk is smouldering fires
- Optical smoke detectors are deemed unsuitable (see 'False Alarms' below)
- The fire compartment is greater than 50 m²

Typical applications include hotel bedrooms, halls of residence, sheltered accommodation and hospital wards.

How CO detectors work

The electro-chemical cell is a simple two electrode design and consists of a semi-permeable diffusion membrane, a reservoir of acid electrolyte, a sensing electrode and a counter electrode.

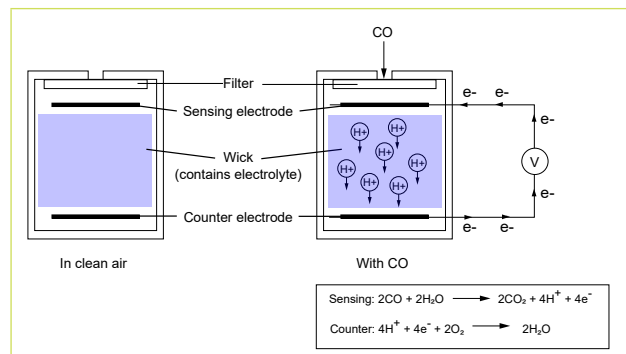

CO diffusing into the cell reacts at the surface of the sensing electrode producing, as a by-product, a number of ions (H+) and electrons (e-). The ions travel through the acid electrolyte to the counter electrode whilst the negatively charged electrons travel to the counter electrode via the external circuit. Combining the electrons and ions at the counter electrode completes the reaction without any of the cells components being consumed. The amount of electrons produced is directly proportional to the amount of CO present, so measuring the current flowing through the external circuit is a basic gas monitor.

Detector siting

CO fire detectors should be sited using the recommendations for smoke detectors from BS 5839 Part 1 or other applicable code.

In the development of a fire, smoke and CO in the smoke plume is spread by convection to a fire detector. As CO is a gas it further spreads - like smells - by diffusion. For this reason CO may reach a detector faster than smoke would. This potential advantage can be exploited when designing a fire protection system and CO detectors may be used for supplementary detection. Equally, the opposite effect might occur with CO moving away from a detector.

The behaviour of CO is therefore unpredictable and diffusion should not be relied upon when designing a fire protection system.

False alarms

CO detectors are less susceptible than smoke detectors to false alarms from sources such as toast, steam, cooking, plumbing work and hairspray. They may therefore be used

in some applications in which smoke detectors would be susceptible to unwanted alarms.

Conversely, they may be more susceptible than smoke detectors to false alarms from fumes containing CO such as vehicle exhausts, open fires and gas appliances.

Limitations

CO detectors also have important limitations. They are set to a higher sensitivity than the maximum allowed by the domestic alarm standard and will respond to CO from faulty gas appliances or vehicle exhausts.

These detectors **should not** be used in place of CO alarms complying with BS 7860 or UL 203.

Operating modes

The Discovery CO detector has five operating modes, each having a set combination of sensitivity and response delay which the user can select for any given application.

Mode	Alarm threshold (ppm)	Min: time to alarm (secs)	Typical application
1	30	60	Sleeping risk with no ambient CO
2	45	30	General use fast response such as supplementary protection in atria
3	45	60	General use and sleeping risk with some low-level CO (such as from light smoking or unventilated gas fire)
4	60	30	General smoking area and supplementary detection of deep seated fires such as laundry rooms
5	75	30	Supplementary use in kitchen or boiler room

Note: A 30 second stabilisation period should be allowed after power-up in order to obtain valid data.

Drift compensation

In view of the inherent stability of CO cells there is no need for Discovery CO detectors to compensate for drift. Discovery CO detectors are set to report a drift value of 16.

Cell test

The Discovery CO fire detector has a remote test feature which is used to verify that the electro-chemical cell is fitted and that it is active.

A test must be done at least once a year but preferably more frequently to ensure that the cell has not dried out.

Note: The cell will not be affected by the test, even if the remote test is done once per day.

If the test indicates a sensor failure, i.e. the detector returns a pre-set analogue value of 25, the detector should be returned to the Apollo Service Department for cell replacement and detector recalibration.

When doing the cell test a 30 second stabilisation period should be allowed after power-up.

The Discovery CO Detector cell has a typical cell life of five years assuming that regular checks are satisfactory.

Precautions when investigating alarms



CAUTION: Investigating alarms

Extreme care must be taken when investigating alarms from CO fire detectors even if no combustion products can be seen or smelled.

It is important to remember that CO is a colourless, odourless gas which is not directly detectable by human senses. If a CO fire detector is in an alarm condition it is possible that a dangerous level of CO exists around the detector.

Because of this danger it is imperative that CO fire detectors are correctly identified at the control panel so that personnel investigating alarms may take the relevant precautions.

Maintenance and service

The electro-chemical cell used in the Discovery CO fire detector has a more limited life than would normally be expected from a smoke detector. In a typical environment the life of the cell is five years.

High temperature or low relative humidity can however reduce the life significantly. The limits given in the section 'Technical Data' should be carefully observed.

It is essential that systems using CO fire detectors be correctly maintained and that the maintenance schedule includes functional testing of the CO fire detectors.

CO aerosol test gas (Part No. 29600-235) is available for this purpose. The test gas should be used with smoke detector tester (Part No. 29600-100).

Health and Safety guidelines

This product contains a sealed electro-chemical cell and in normal usage represents no chemical hazard in the sense of COSHH and the Health and Safety at Work etc. Act 1974. Chemical hazard can however arise if the notes on storage, handling and disposal that follow are not observed.

For maximum life the product should be stored before installation in clean, dry conditions between 0°C and 20°C. It should not be exposed to temperatures outside of the range -40°C to +60°C or to organic vapours.

The electro-chemical cell contained in this product is fitted into sockets on the printed circuit board. To avoid damage to the cell do not remove it.

The electro-chemical cell contains sulphuric acid in a relatively concentrated state. In the event of leakage (which may be caused by mechanical damage or use outside the operating specification for the cell), the cell should be removed from the detector using protective gloves. Avoid contact with any liquid. If skin or eye contact with the electrolyte occurs wash immediately with plenty of water and obtain medical advice. All traces of electrolyte should be washed away with copious amounts of clean water. The cell should be disposed of according to local waste management requirements and environmental legislation. It should not be burnt as it may release toxic fumes.

EMC Directive 2014/30/EU

The Discovery CO Detector complies with the essential requirements of the EMC Directive 2014/30/EU, provided that it is used as described in this datasheet.

A copy of the Declaration of Conformity is available from the Apollo website: www.apollo-fire.co.uk.

Conformity of the Discovery CO Detector with the EMC Directive, does not confer compliance with the directive on any apparatus or systems connected to them.